

GLYDEA 35E WT/RTS

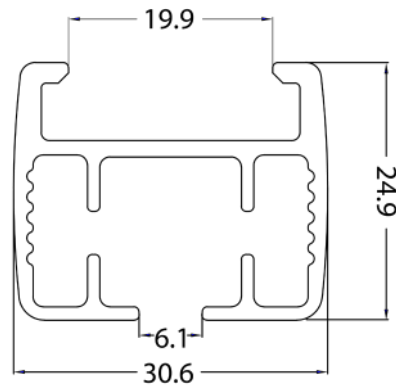

SPECIFICATION







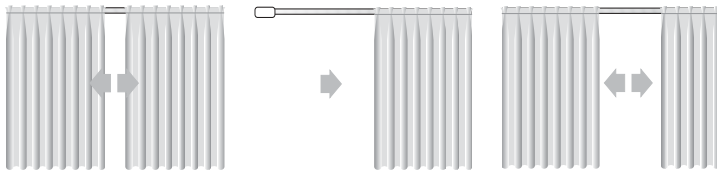



- Width 30mm; Height 25mm
- Traversing Capacity 35kg, NM = 0.6NM, RPMs =105
- Maximum curvature of 90° curves: 30cm; wide radius curves: 50cm
- Available in multiple technologies (WT/DCT/RTS and bidirectional technology with RS485)
- Manual override system in event of power failure
- Soft start and Soft stop with RTS and DCT motors
- Compatible with 80mm S-Fold Gliders
- Noise Operational: 29.8-45.2 dBA
- 5 adjustable speeds available
- Track colours: White



OPENING OPTIONS



WEIGHT RANGES

 Kg	3m	6m	10m	 Kg	3m	6m	10m
	35 Kg	35 Kg	35 Kg		15 Kg	10 Kg	...
	35 Kg	35 Kg	35 Kg		15 Kg	10 Kg	...
	35 Kg	25 Kg	20 Kg		35 Kg	15 Kg	...
	35 Kg	25 Kg	20 Kg		30 Kg	10 Kg	...