

# 1.12b Fully Enclosed Multilink Kasset

## Technical Information

1. Face rail cover plate Extruded aluminium manufactured to ISO9001.
2. L rail section Extruded aluminium manufactured to ISO9004.
3. Headrail endcaps Moulded from U.V. resistant acetal.
4. Multilink endcaps Moulded from U.V. resistant acetal.W
5. Male link 'unidrive' connector Extruded aluminium manufactured to ISO9001.

## Dimensions & Limitations

MINIMUM WIDTH\* 600mm  
MAXIMUM WIDTH\* 5800mm

## Componentry

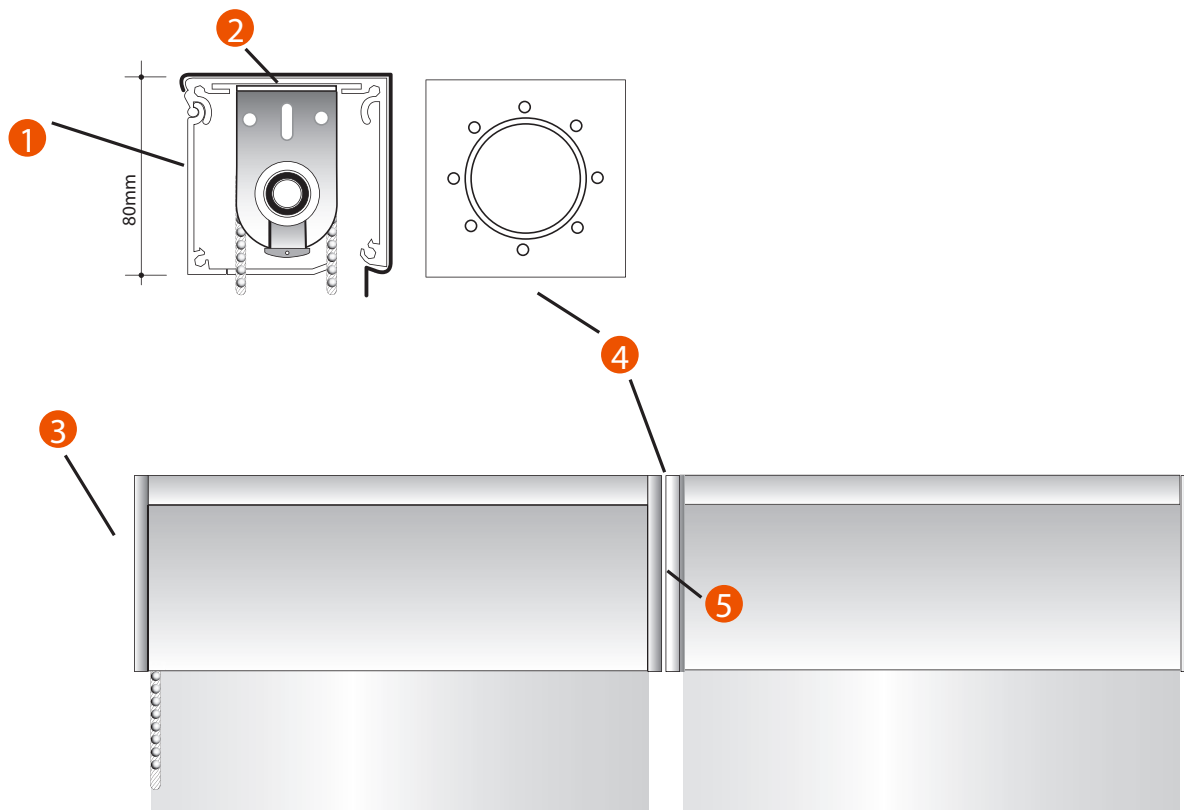

## References

