

# 1.11a Single Fascia Kasset

## Technical Information

1. Fascia kasset Extruded aluminium manufactured to ISO9001.
2. Fascia kasset end caps Moulded wear-resistant polycarbonate.
3. Bracket Spring loaded pressed zinc coated steel.

## Dimensions & Limitations

MINIMUM WIDTH\* 600mm  
MAXIMUM WIDTH\* 5800mm

**Note: Sizes with Fabric widths typically over 3000mm will void warranty.**

## Componentry

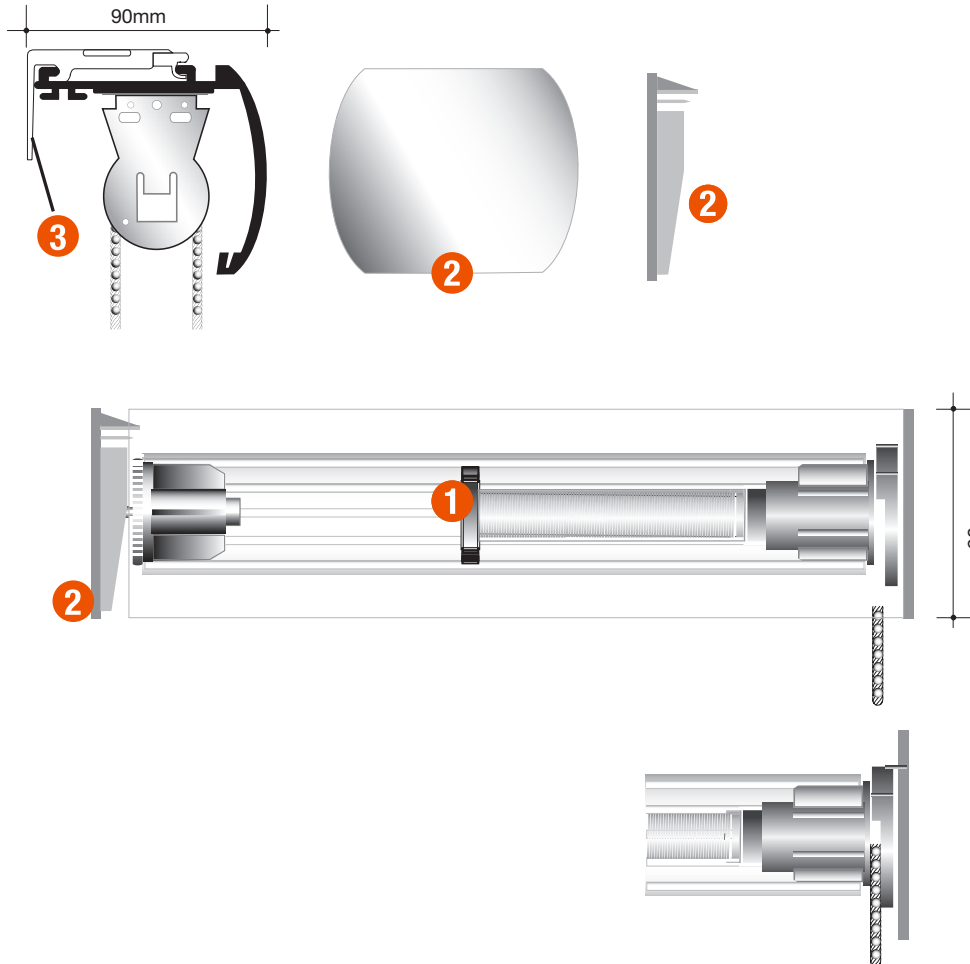

## References

